

## MiCAT PLANNER

EFFICIENT PART PROGRAM GENERATION

COORDINATE  
MEASURING  
MACHINES

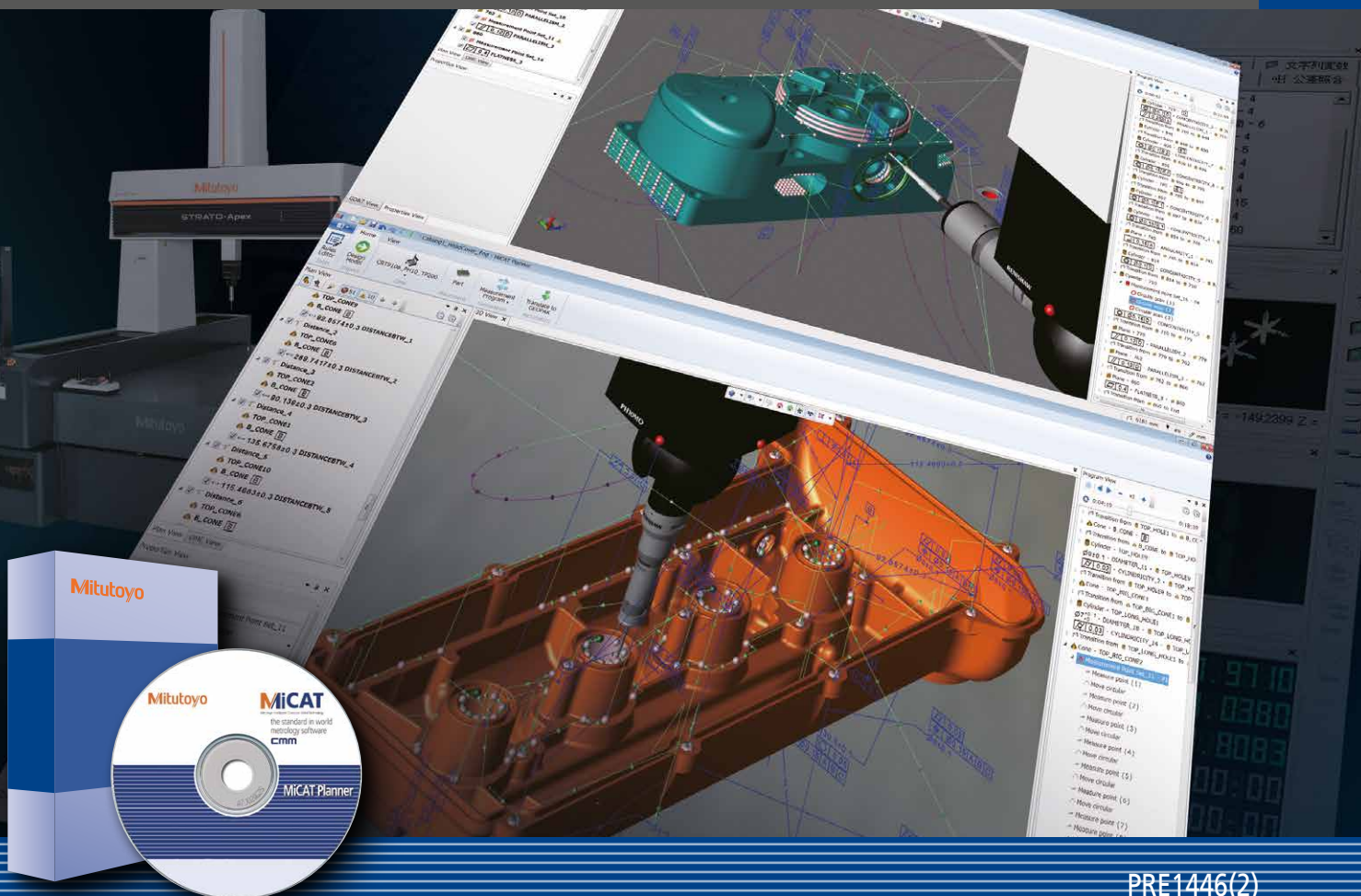

## Part programs – easy, fast and reliable.

Creating part programs for coordinate measuring machines is a strategic and time-consuming task.

Programming in a conventional way can result in misinterpretation of design intent. Complex part programs require path optimisation in order to avoid a waste of time. Plus, the work of different programmers can result in discrepancies. Mitutoyo MiCAT Planner – the perfect antidote!

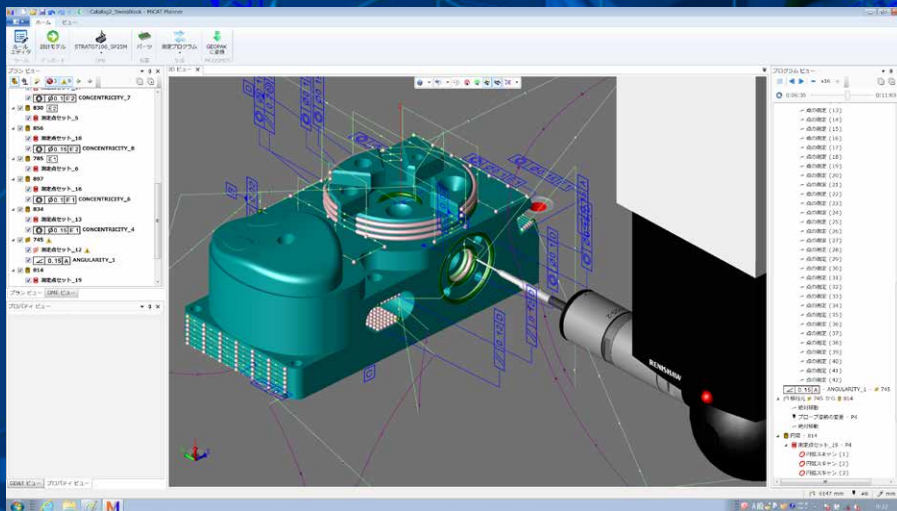

Shorter product lifecycles require rapid change to design revisions and fast programming capability;  
Increasing machine up-time requires more efficient programs and reduced set-up time.

The Mitutoyo CMM programming software MiCAT Planner meets all these demands.

**Generate your CMM part programs with unprecedented efficiency:  
the Mitutoyo software MiCAT Planner**

The all-new Mitutoyo MiCAT Planner drastically reduces programming efforts in working out part programs for coordinate measuring machines. The software's automatic measuring program generator saves vast amounts of time and cost.

**Features:**

- Identifies tolerance information included in 3D models with Product and Manufacturing Information (PMI), defines measurement locations and creates a measurement program fully automatically.
- Through its optimisation function, the software estimates the shortest route for measurement with the minimum of probe repositioning and tool changing, and creates a program that enables measurement in the minimum possible time.
- Utilizing the rule editor function to set the measurement rules prevents variation in measurement quality between program writers.

DME: Virtual model of the CMM incl. all probe configurations.

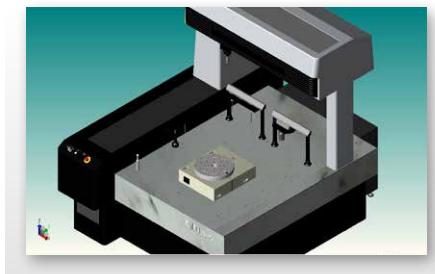

User-defined rules determine the measurement strategy automatically for each feature.

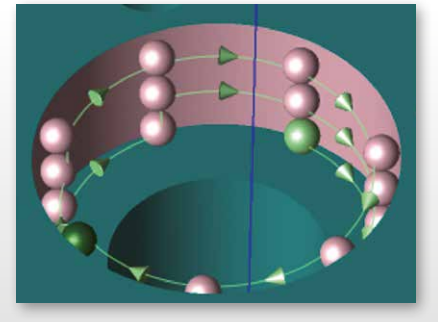

PMI: CAD file containing tolerance information.

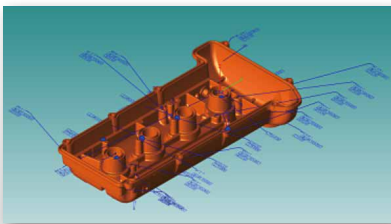

**Instant and automatic generation  
of measurement programs.**

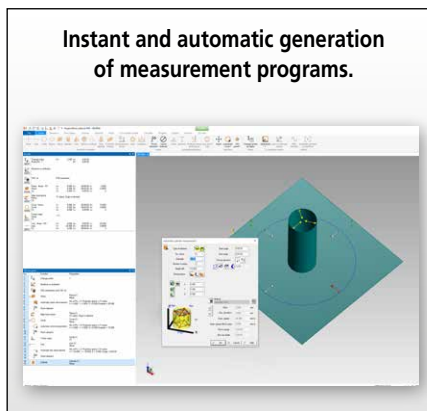

# MiCAT Planner – For You!

The Mitutoyo MiCAT Planner boasts amazing performance, speed and usability. But is it suitable for your demands?

YES!

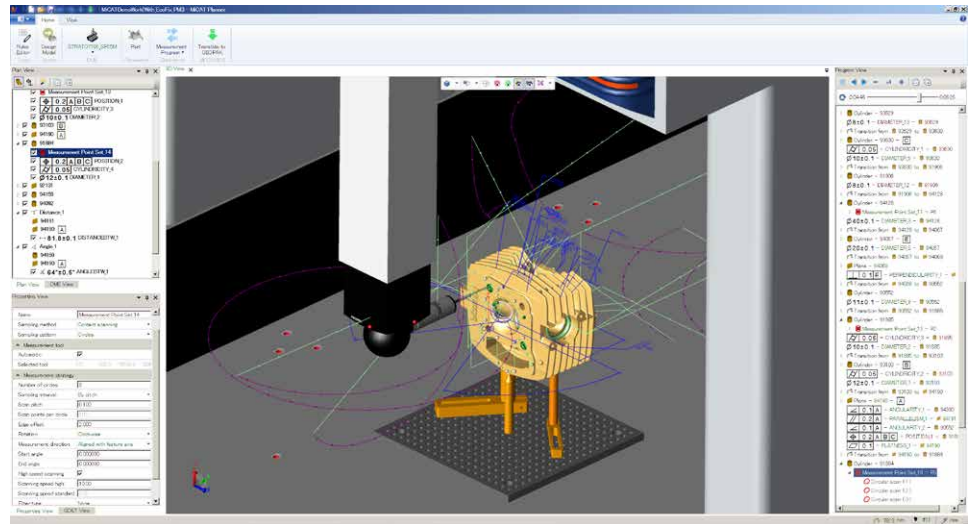

**“We only work on short or midsize runs, is it really useful?”.**

✓ Yes, MiCAT Planner will dramatically shorten your programming time!

**“I only inspect out-sourced parts and never evaluate the same characteristics: is MiCAT Planner appropriate in this case?”**

✓ Yes, MiCAT Planner will help you creating various part programs, including different features, in a twinkle!

**“Our production is quite stable on long runs, we rarely need to create programs for new components on our CMM, are you sure MiCAT Planner may help? ”**

✓ Yes, MiCAT Planner will definitely help because your CMM operators are not familiar with part-programming: safe, consistent and optimised part programs are guaranteed by MiCAT Planner!

**“We have many CMM programmers, why should we need MiCAT Planner?”**

✓ MiCAT Planner will bring you a higher quality result in your measurement tasks: thanks to the unlimited measurement rules, you can trust the program will always be developed the same way, whoever creates it!

**Regardless of your measuring tasks, MiCAT Planner adds an abundance of benefits to your CAD-based programming.**



# Real CMM Configuration



The program acquires the current actual CMM configuration from the CMM driving software MCOSMOS.

All racks and probes of the machine are exactly represented and taken into account, exactly as they are.

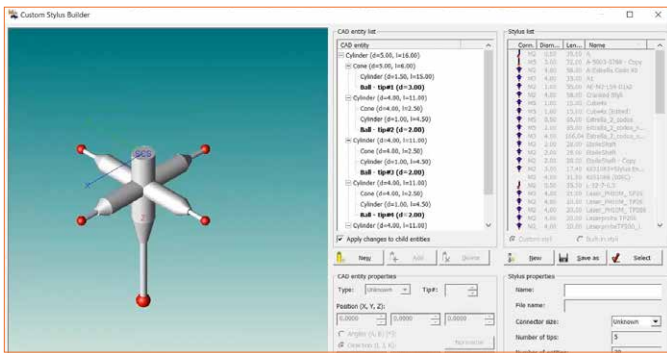
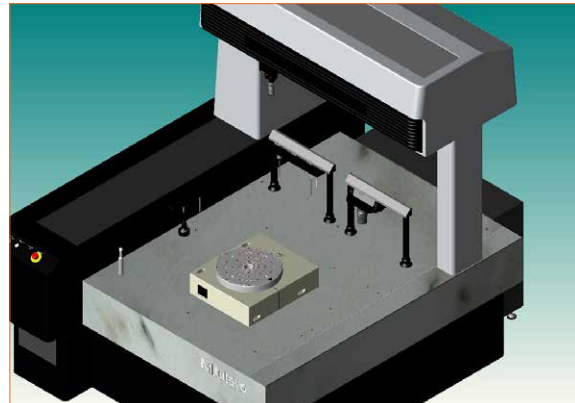

MiCAT Planner selects the best-suitable probe configuration for each feature under consideration of the customised measuring rules.

This virtual reality allows the automatic avoidance of each rack zone. Even long styli can be avoided when hanging in the rack, intruding in the measuring volume.

# Measurement Strategy

One of the main benefits you obtain from MiCAT Planner, is the compliance to measuring rules you may set as you need.

Depending on the feature type, size or other criteria, you may decide the number of measuring points, their distribution, and even the scanning speed when applicable.

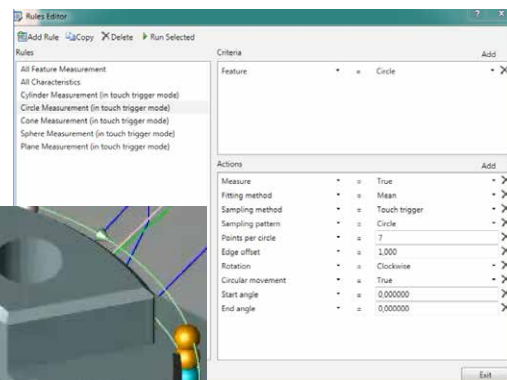
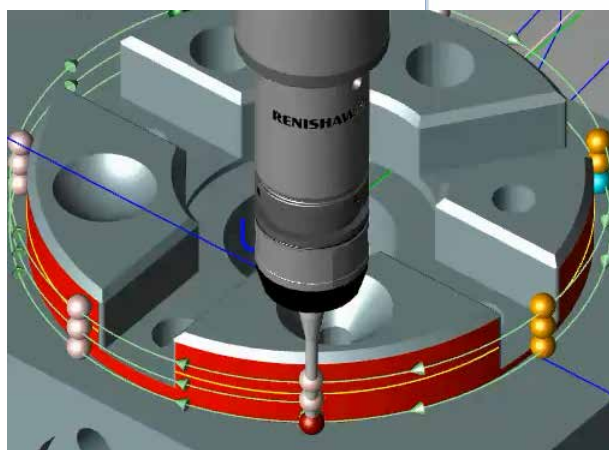

Several sets of rules can be applied simultaneously, for example according to the component manufacturing method or the customer for which you produce it.

# CAD Data Information: Automatic or Manual

After importing the CAD model, either all required features and GD&T are available thanks to the PMI data (Product Manufacturing Information) or they are partly or totally missing.

When using a CAD model including PMI Data, all required features and characteristics to be evaluated are instantly displayed and available: automatic part program generation can start right away!!

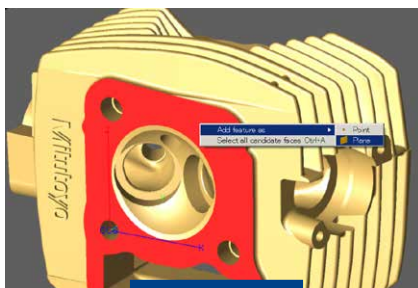
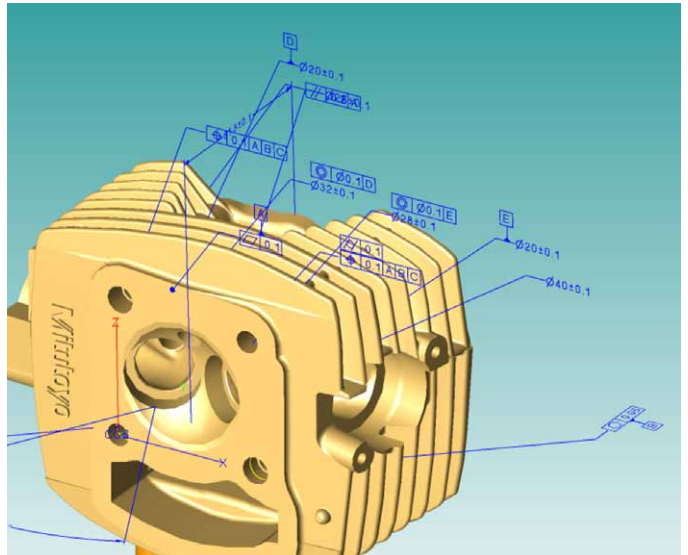

**Add feature**

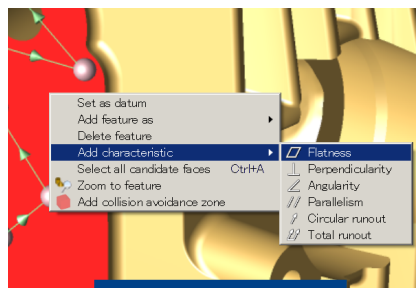

**Add characteristic**

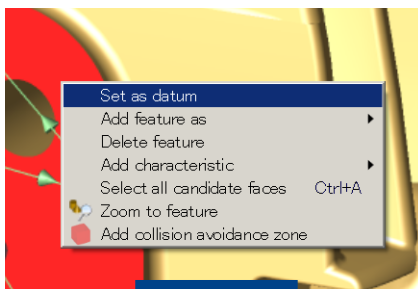

**Add datum**

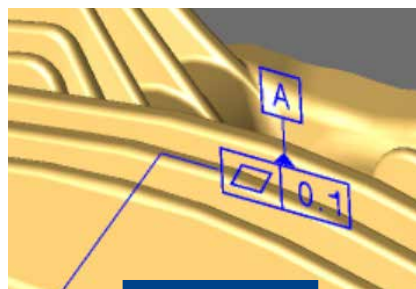

**Display result**

In case the CAD model lacks features and characteristics, manual inputs are easy and quick thanks to the GD&T wizard.

Edition of tolerance values is also available.

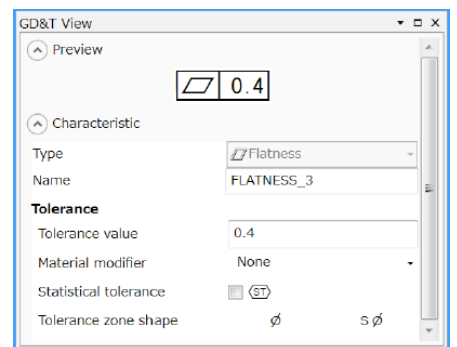

# Automatic Part Program Generation!



Once all features and characteristics to be evaluated are validated and approved by the CMM programmer, the part-program is generated automatically.

The plan view (left) is detailed in the program view (right), and both are synchronized with the 3D view (center).

When you select a feature or characteristic in any of these views, MiCAT Planner clearly indicates where you are in the two other views.

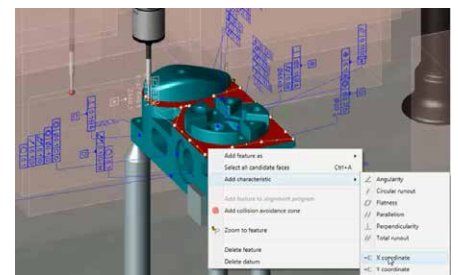
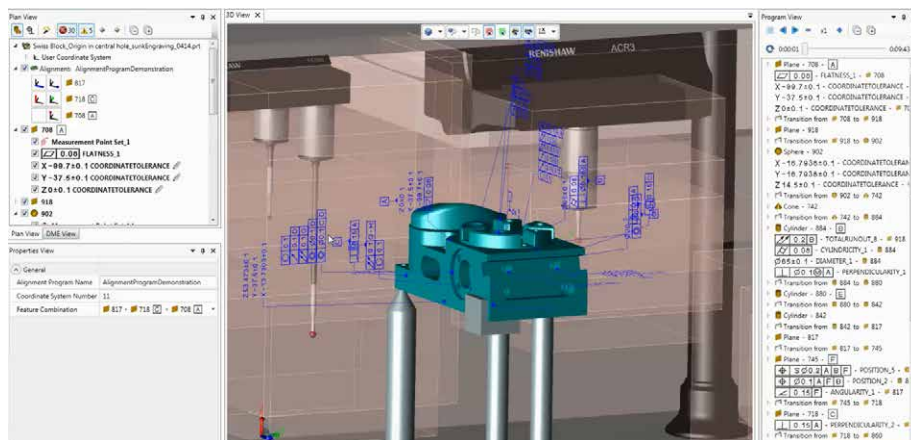

If required, a missing feature (not identified on the CAD model) or a missing characteristics to be evaluated can be manually added from the 3D view.

# Safe GD&T Interpretation

CAD designed components are more and more defined by form and position symbols according to international standards.

However, depending on the individual programmer skill level, it may lead to different or inconsistent interpretation in the part program strategy.

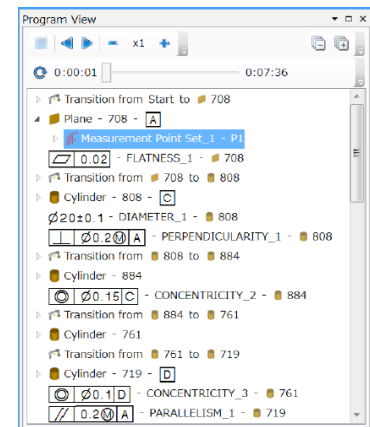
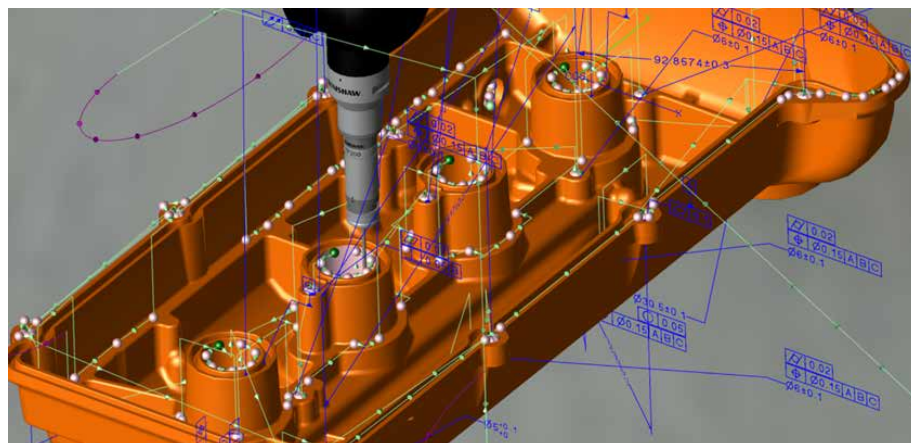

MiCAT Planner prevents from any misinterpretation risk: each GD&T symbol, tolerance and datum is automatically understood and converted in the corresponding required measurement points.

In the program view, all GD&T are shown in regards to the feature to be measured for calculating the result.

# Cycle Time Optimisation

When programming manually, the programmer creates a cycle following the required features for calculating the expected results.

Very frequently, this results in unnecessary CMM movements and inappropriate probing paths. Consequently, it may waste a precious time better used for effective measuring tasks.

First MiCAT Planner generates the probing path according to the feature's list order, and then optimises it according to best strategy, avoiding redundant probe change or movement.

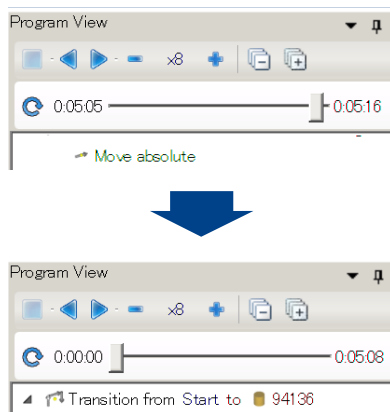
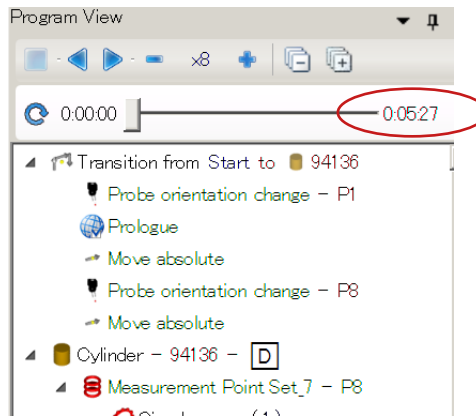
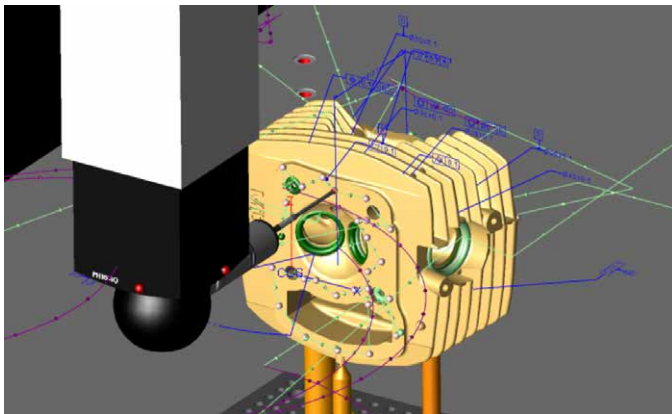

Furthermore, MiCAT Planner automatically estimates the measuring cycle time according to the actual CMM configuration and settings. For example, the required time for exchanging a probe in the rack, or the specified scanning speed in your measurement rules are considered for this time estimation. Immediately after the cycle optimisation calculated, the estimated new cycle time is displayed.



... and much more!

### Avoidance zone

Several avoidance zones can be created to simulate the presence of any obstacle like a clamp, a bracket or a column simulating a fixture. MiCAT Planner will automatically calculate probing points and path to avoid all these areas, providing a collision free part-program!

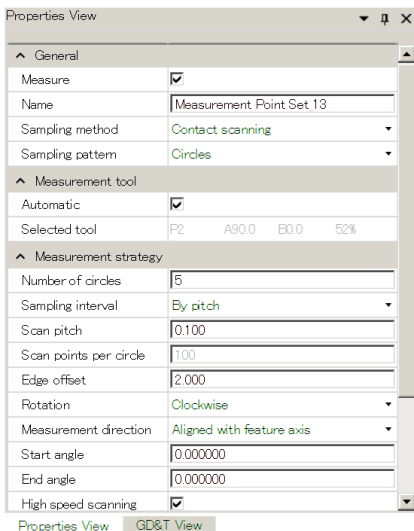
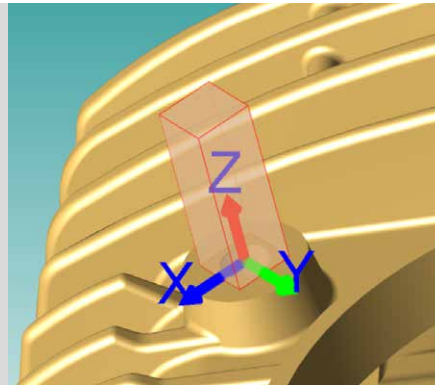

### Individual measurement edition

If for any reason a feature can't be measured correctly because no rule is planned for this particular case, every detail of the probing strategy can be edited.

MiCAT Planner will consider this as an exception for a given feature, but will keep on applying existing rules to all other features of this kind.

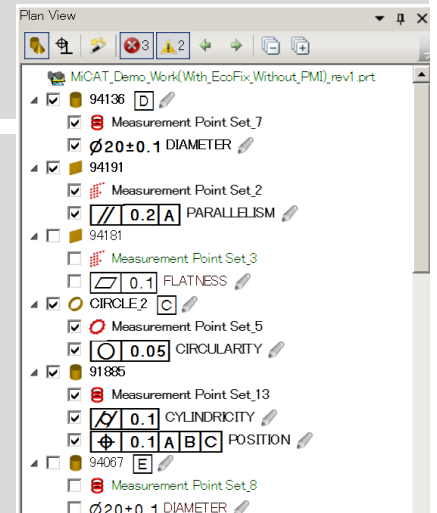

### Flexible Measurement Selection

While MiCAT Planner always selects the maximum number of features to measure, the user may decide to disable / enable unnecessary features by unchecking / checking the corresponding boxes. Drag and drop functionality is also available here for manual reorganisation of the measurement order.

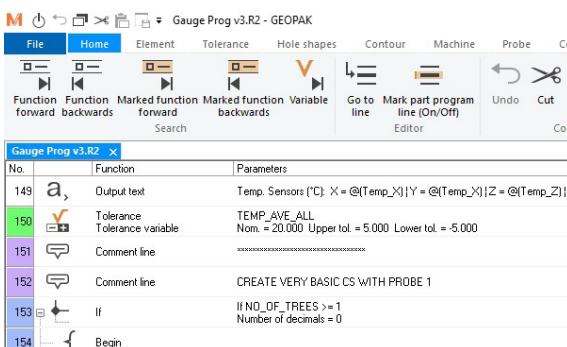

### Editable Part-Program

Once generated from MiCAT Planner, a part-program can be managed and edited in MCOSMOS, like any former part-program.

# Return On Investment

Using MiCAT Planner means saving your programming time, and time is money. But how much saving can you expect?

Two different scenarios display your savings potential.

## CAD model without PMI Data

- Number of measured features = 17
- Number of evaluated characteristics = 22
- Programming time with MCOSMOS = 51'
- Programming time with MiCAT Planner = 23'

Time saving = 28'  
→ 55%

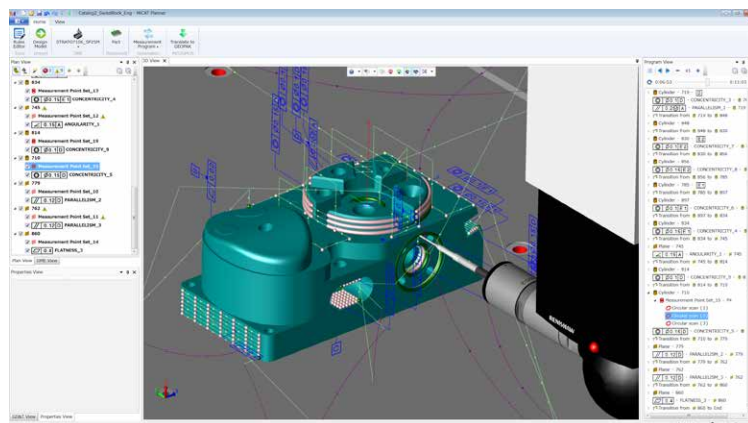
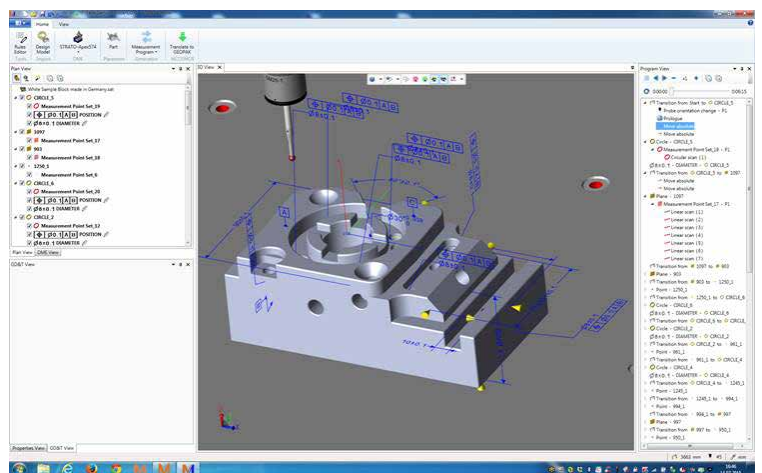

## CAD model with PMI Data

When PMI Data are imported (GD&T) the number of features and characteristics has a very low influence on the part-program generation time.

In this example:

- with MCOSMOS = 43'
- with MiCAT Planner = 3'

Time saving = 40'  
→ 93%

# Screen setups and features

MiCAT Planner screen setups offer simple interfaces such as 3D view and plan view, thereby enabling intuitive operation. The placement and window sizes of the interfaces can be freely customized.

**3D view**

Full-color graphics show:

- Measuring machine details
- CAD model with tolerance information
- Measurement points and measurement paths
- Measurement animations

**Plan view**

- Shows lists such as measurement parameters and tolerances.
- Lets you flag measurements and assessments using check boxes.

**Properties view**

You can change the names of parameters, tolerance items and measurement points, and edit measurement points for individual parameters.

**Program view**

- Shows measurement details and measurement estimation times.
- Enables animation of measurement programs in 3D view.

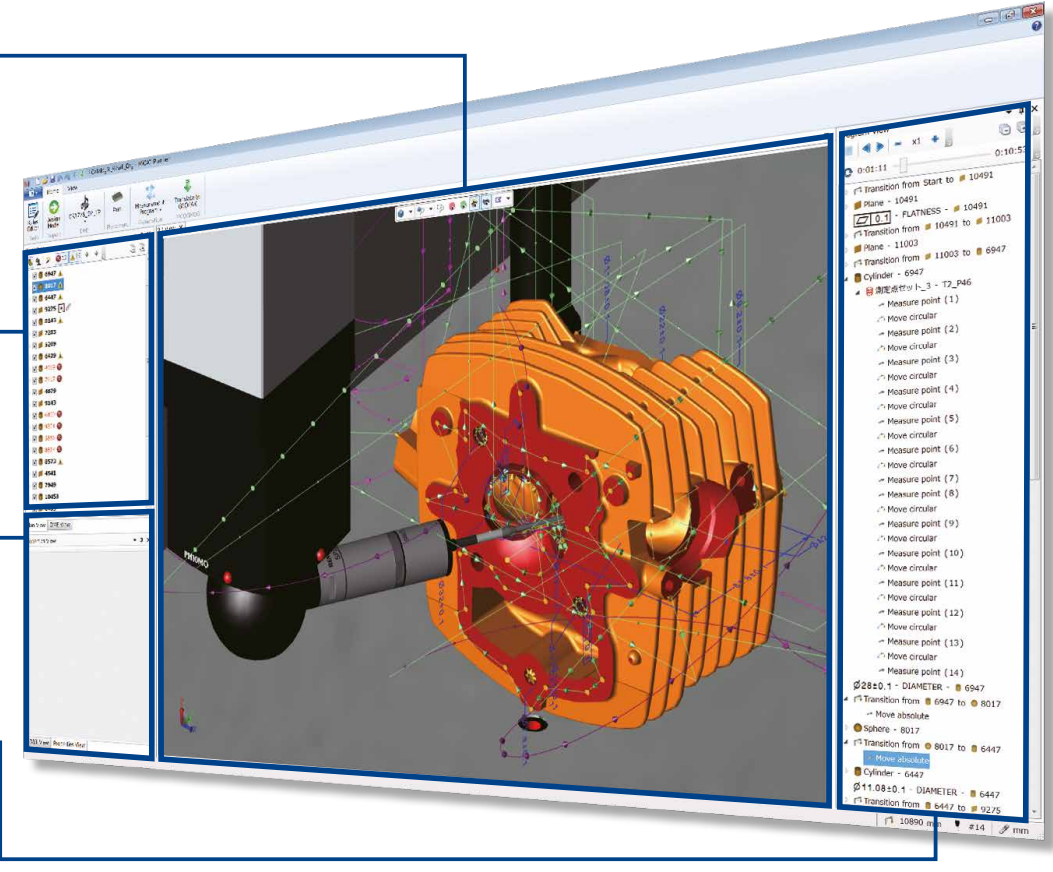

## Case study

### 1. Conventional method

Compare the measurement part-programming time for a test piece.

1-1) Programming in 2D drawing: **approx. 45 to 60 minutes**

1-2) Programming using 2D drawing + 3D CAD:  
**approx. 15 to 20 minutes**

### 2. With MiCAT Planner

Create with **MiCAT Planner** (using 3D CAD model + PMI):  
**approx. 3 minutes!**

Note: The measurement rules are defined in advance.

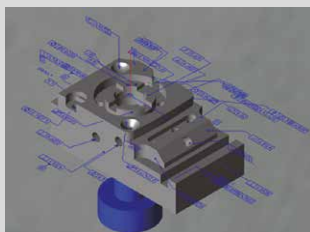

Part-programming time  
**Reduced by up to 95% !!**

Guarantee a **dramatically reduced development phase** and at the same time improve product quality.

## CAD formats currently supported:

MiCAT Planner supports 3D CAD files of closed solid models and GD&T informations when available

CAD file Formats	File Extension	Supported Versions
Siemens PLM NX/Unigraphics	*.prt	NX 1 – NX 1953
PTC Pro/Engineer/Creo	*.prt or *.prt.*	16 – Creo 7.0
Dassault Systems CATIA V5	*.CATPART	V5R8 – V5-6R2021
ACIS*	*.sat	R1-2021 1.0.0.16
SolidWorks	*.sldprt	2003-2021 without PMI 2014-2021 with PMI
STEP	*.stp or *.step	AP203 without PMI AP214 without PMI AP242 with PMI

\*PMI contained in ACIS files is supported if the model was saved from CAT1000 (MCOSSMOS). PMI created in CAT1000's "Define GD&T wizard" is not supported. PMI contained in ACIS files that were generated from other software applications is not guaranteed to be imported.

Note: ACIS and STEP CAD formats are standard, other CAD file formats are optional.

## Supported languages

Japanese, English (US/UK), German, French, Spanish, Portuguese, Italian, simplified Chinese, traditional Chinese, Korean, Polish, Czech, Dutch, Turkish, and Russian

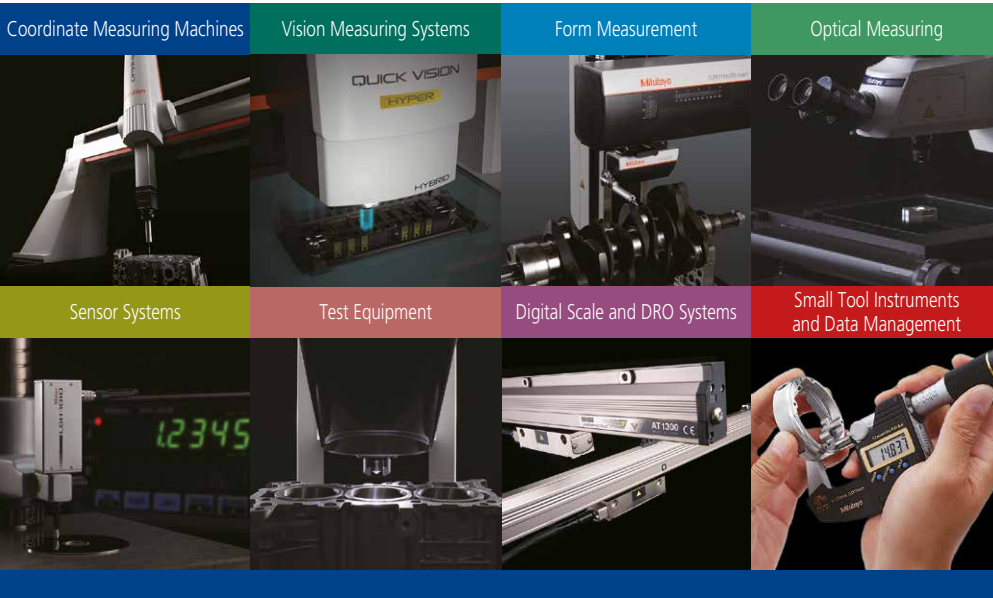

## Whatever your challenges are, Mitutoyo supports you from start to finish.

Mitutoyo is not only a manufacturer of top quality measuring products but one that also offers qualified support for the lifetime of the equipment, backed up by comprehensive services that ensure your staff can make the very best use of the investment.

Apart from the basics of calibration and repair, Mitutoyo offers product and metrology training, as well as IT support for the sophisticated software used in modern measuring technology. We can also design, build, test and deliver bespoke measuring solutions and even, if deemed cost-effective, take your critical measurement challenges in-house on a sub-contract basis.

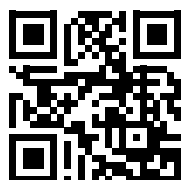

Find additional product literature and our complete catalog here.

[www.mitutoyo.eu](http://www.mitutoyo.eu)

**Note:** Product illustrations are without obligation. Product descriptions, in particular all technical specifications, are only binding when explicitly agreed upon. MITUTOYO is either registered trademark or trademark of Mitutoyo Corp. in Japan and/or other countries/regions. Other product, company, and brand names mentioned herein are for identification purposes only and may be the trademarks of their respective holders.

# Mitutoyo

**Mitutoyo Europe GmbH**

Borsigstraße 8-10  
41469 Neuss

Tel. +49 (0) 2137-102-0

[info@mitutoyo.eu](mailto:info@mitutoyo.eu)  
[www.mitutoyo.eu](http://www.mitutoyo.eu)